

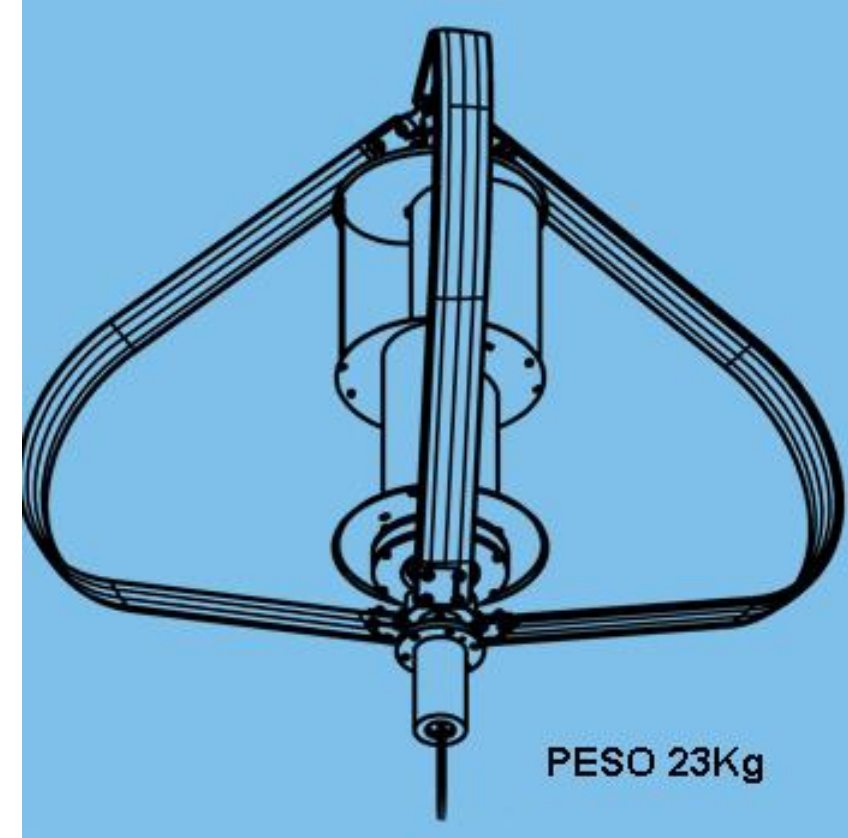

SELF-SUFFICIENT HYBRID LAMPS

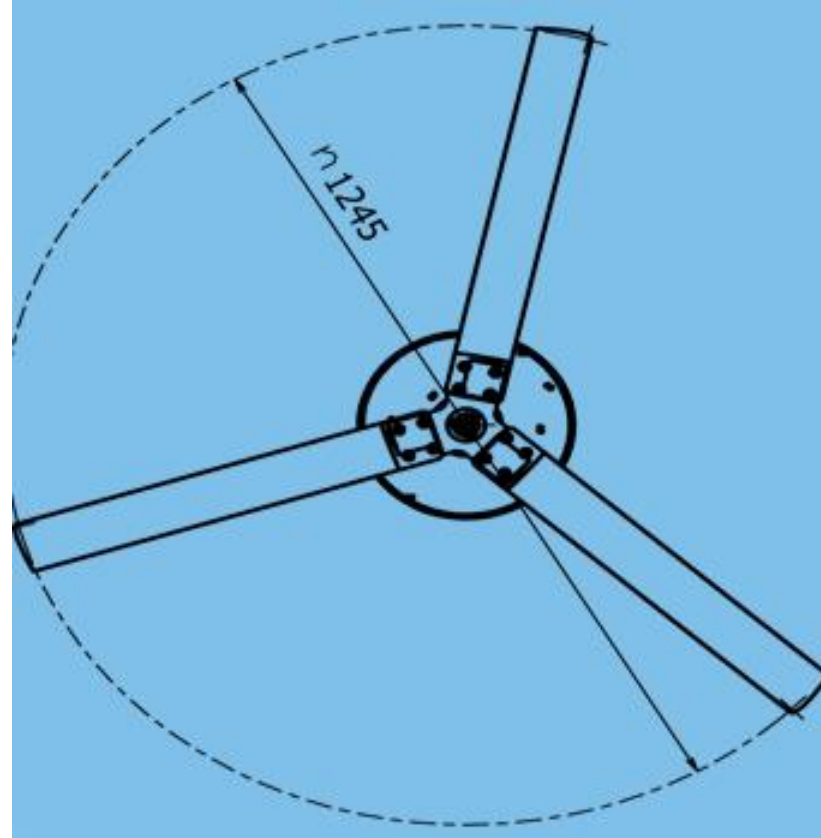

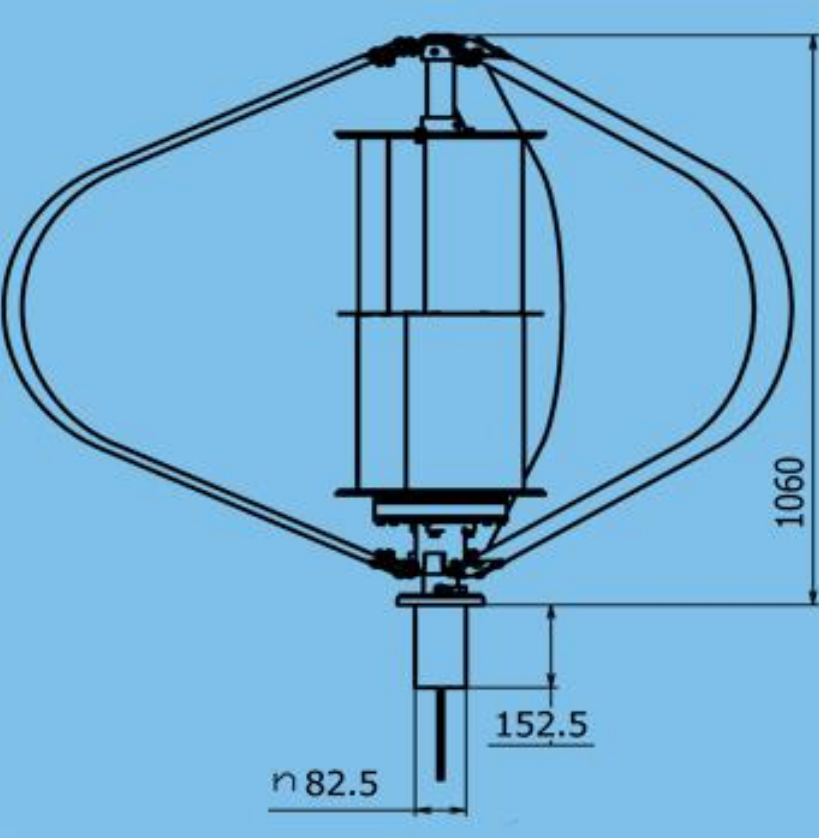

The DS300 turbine is a 500W **vertical axis hybrid micro wind generator**, used in combination with photovoltaics for self-sufficient poles or applications in the absence of electricity.

Vertical
Wind

Power
500W

24V battery
voltage

2-6m pole

Hybrid
technology

<https://www.etneo.com/en/wind-turbine-ds300/>

DS300 The unique hybrid in the micro wind market



1kW VERTICAL WIND TURBINE

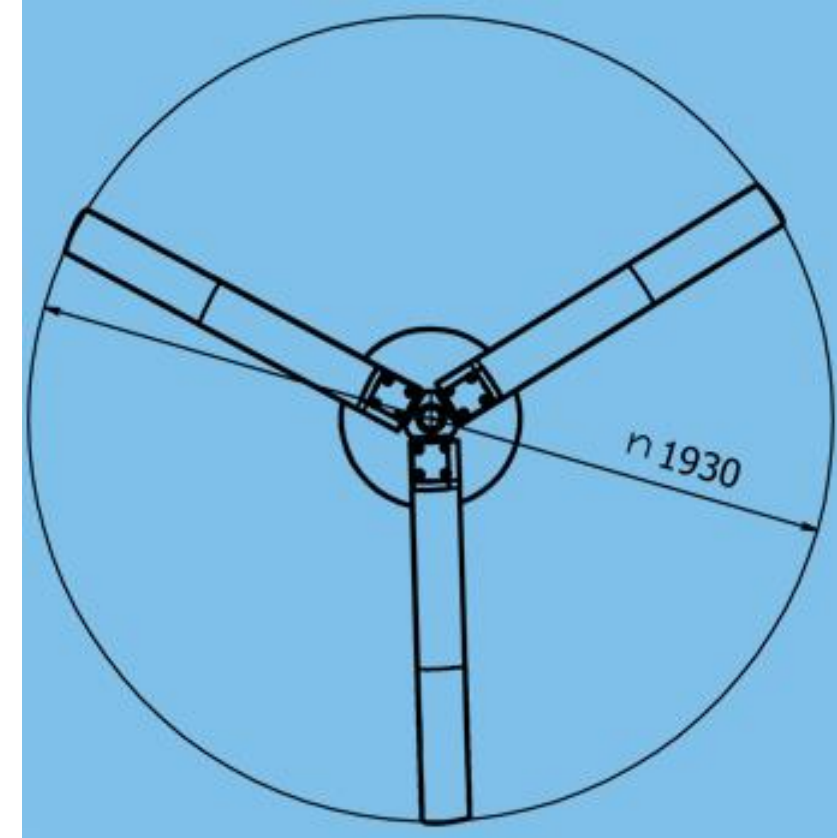
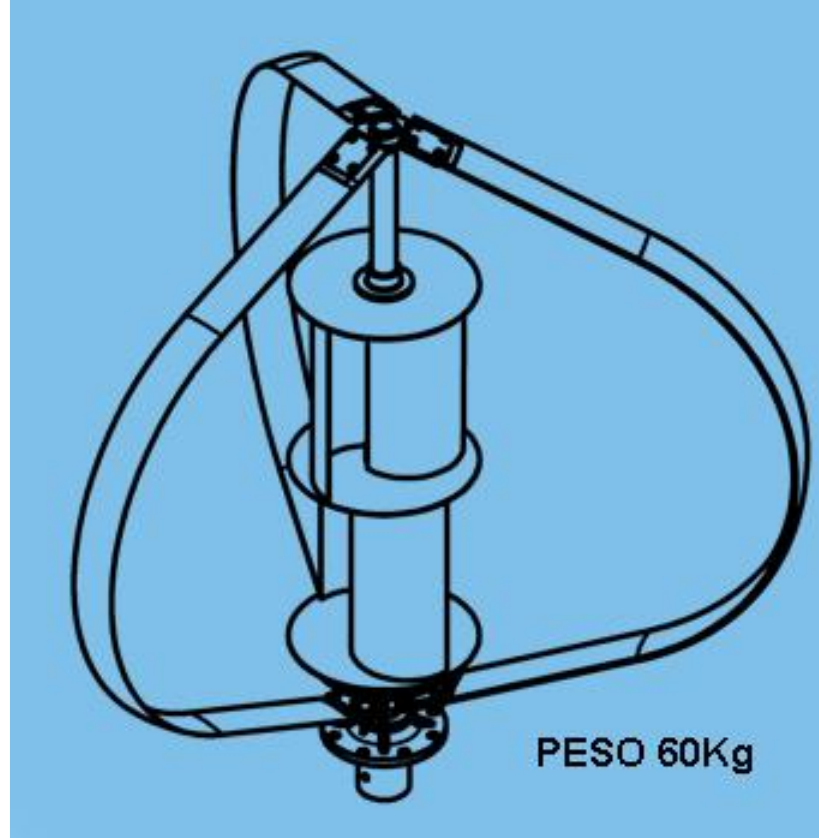
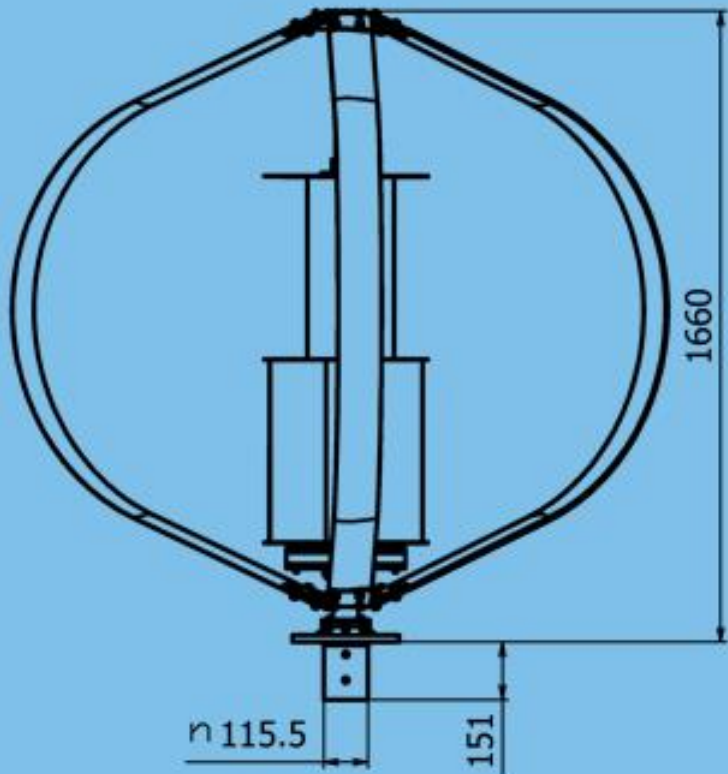

The DS700 turbine is a 1kW **vertical axis hybrid micro wind turbine**, it is used in combination with photovoltaics for residential and commercial small/medium-sized systems.

Vertical
Wind

Power 1kW

48V battery
voltage

2-6m pole

Hybrid
technology

<https://www.etneo.com/en/wind-turbine-ds700/>

DS700 The unique hybrid in the micro wind market





1.5kW HORIZONTAL WIND TURBINE

HAWT 1500 Efficiency light weight minimum overall dimensions

The HAWT1500 turbine is a **1.5kW horizontal axis multi-blade wind turbine**, used in combination with photovoltaics for residential and commercial small / medium-sized plants.

Horizontal
Wind

Power
1,5kW

48V battery
voltage

2-6m pole

5-blade
technology

<https://www.etneo.com/en/horizontal-wind-turbine-1500w/>

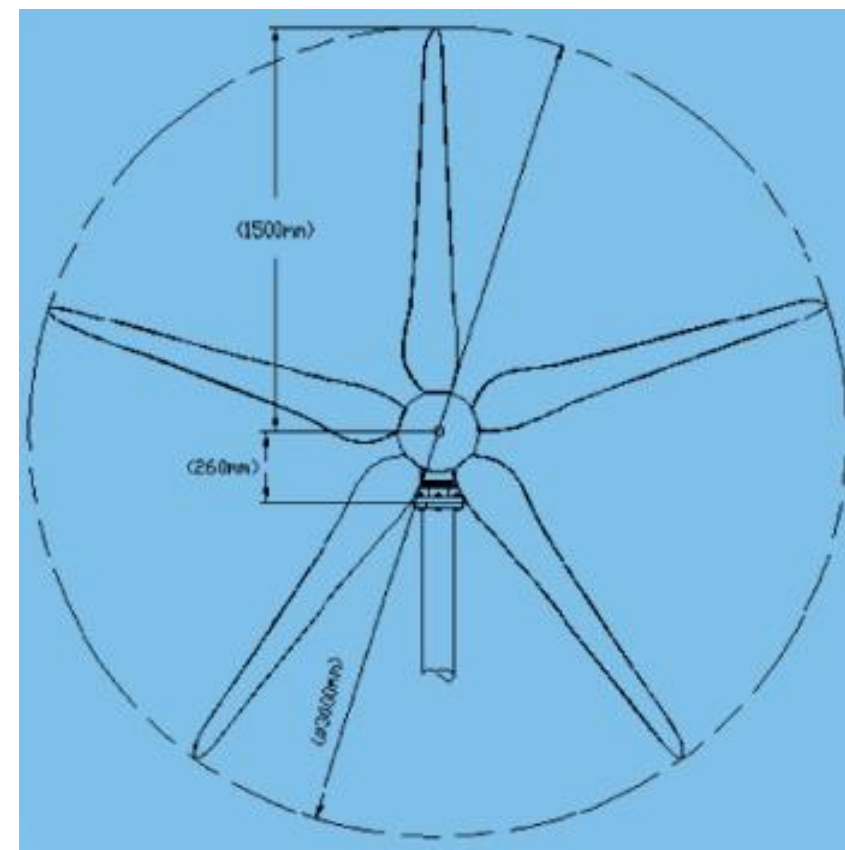
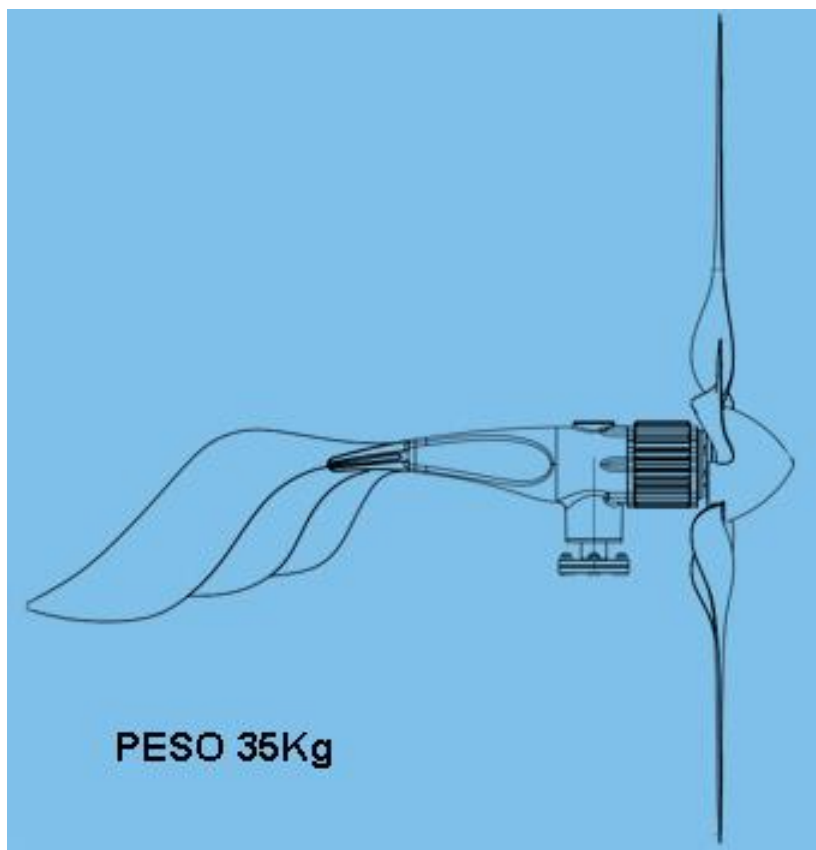
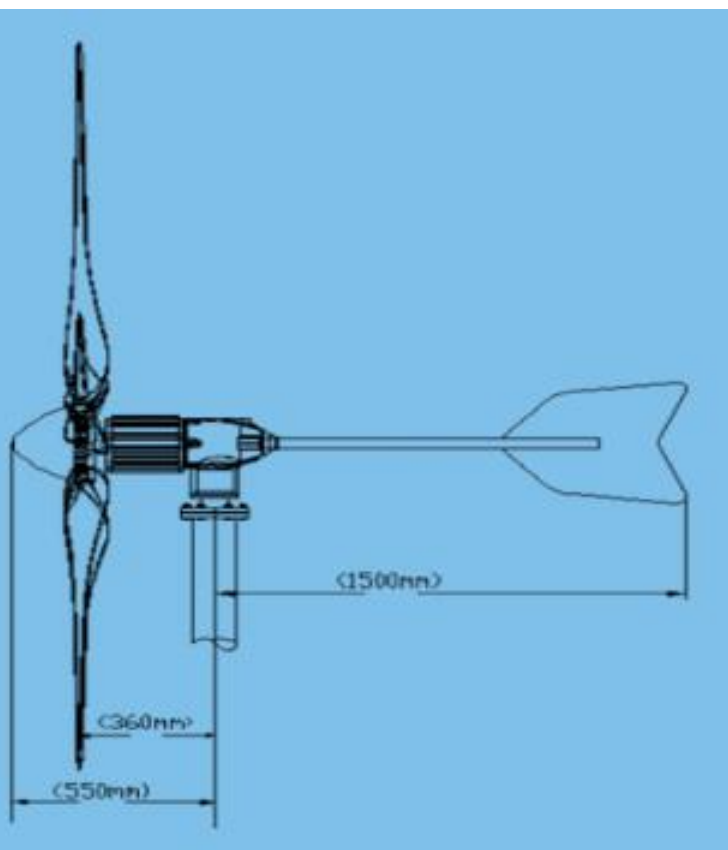





**Etneo Italia Small
wind turbines + solar
panes + storage**



Etneo Italia srl, via Giovanni
Bovio n°6, 28100 Novara, Italy
phone: +39 0321.697.200,
mail: alexdrappo@etneo.com -
<https://www.etneo.com/en/smart-energy/>